

(12) **UK Patent Application** (19) **GB** (11) **2 370 301** (13) **A**

(43) Date of A Publication 26.06.2002

<p>(21) Application No 0130640.6</p> <p>(22) Date of Filing 21.12.2001</p> <p>(30) Priority Data (31) 60257224 (32) 21.12.2000 (33) US</p>	<p>(51) INT CL⁷ E21B 43/08 43/10 43/14</p> <p>(52) UK CL (Edition T) E1F FJF FLW FMU</p> <p>(56) Documents Cited GB 2343691 A GB 2336383 A EP 0360597 A US 6263966 B US 5901789 A</p> <p>(58) Field of Search UK CL (Edition T) E1F FJB FJF FLA FLW FMU INT CL⁷ E21B 43/08 43/10 43/14 Online: WPI EPODOC JAPIO</p>
<p>(71) Applicant(s) Baker Hughes Incorporated (Incorporated in USA - Delaware) 3900 Essex Lane, Suite 1200, P.O. Box 4740, Houston, Texas 77210-4740, United States of America</p> <p>(72) Inventor(s) Martin P Coronado Edward T Wood Benn A Voll Mohamad F Khodaverdian Ray Vincent Van N Ho</p> <p>(74) Agent and/or Address for Service Murgitroyd & Company Scotland House, 165-169 Scotland Street, GLASGOW, G5 8PL, United Kingdom</p>	

(54) Abstract Title
A method for well completion using an expandable isolation system

(57) A well completion method for isolating at least one zone which comprises running into the wellbore a string with isolators 24, 26 in conjunction with a screen 28 which allows flow from the surrounding formation into the string and expanding the isolators and the screen in the wellbore. The isolators are tubular with a sleeve of an elastomeric sealing material. The screen is made of a weave in one or more layers. The completion assembly includes an inflatable expansion assembly which provides a limited expansion force and/or diameter. A plurality of zones can be isolated on a single trip.

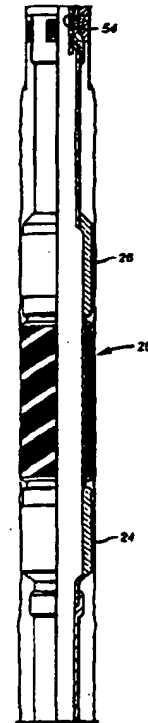

FIG. 5b

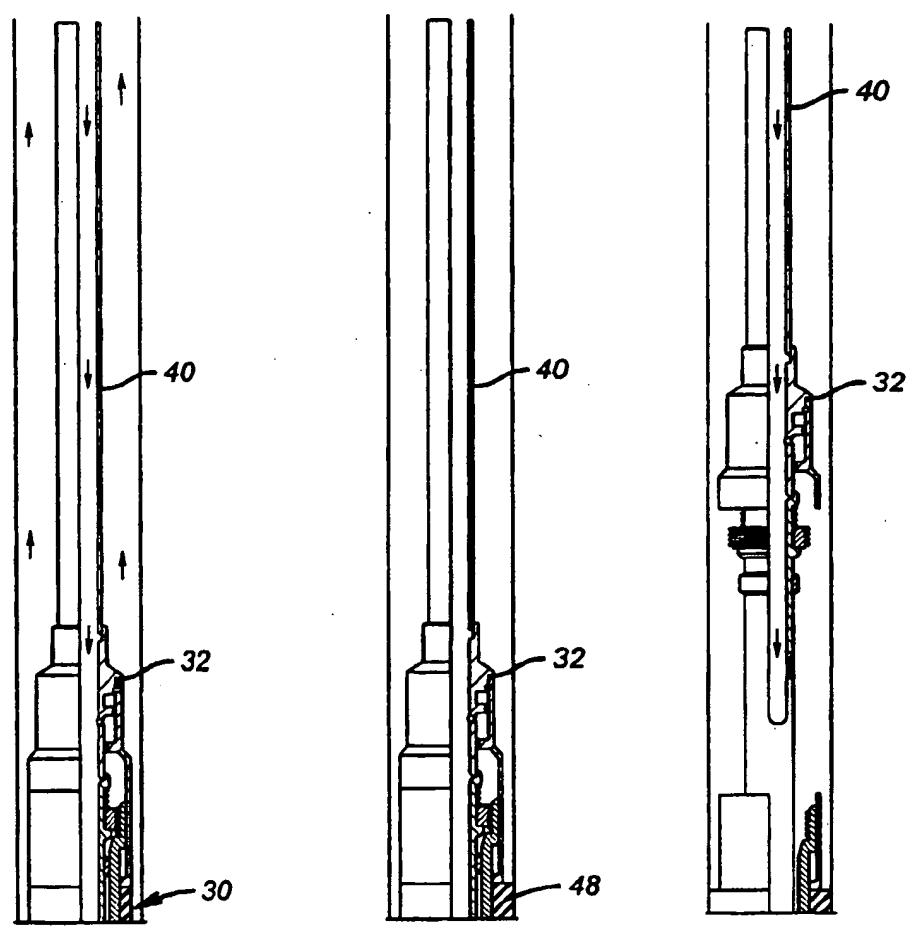

FIG. 1a

FIG. 2a

FIG. 3a

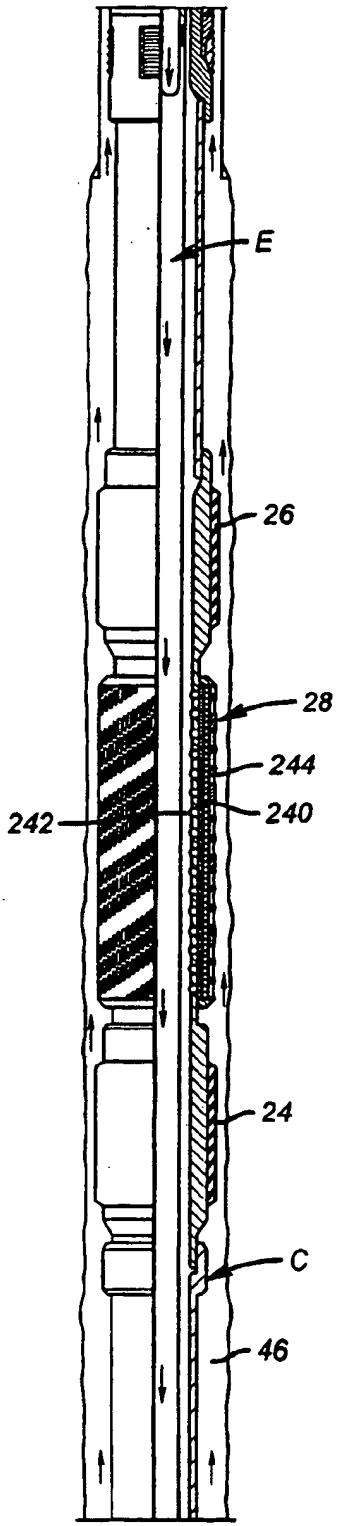

FIG. 1b

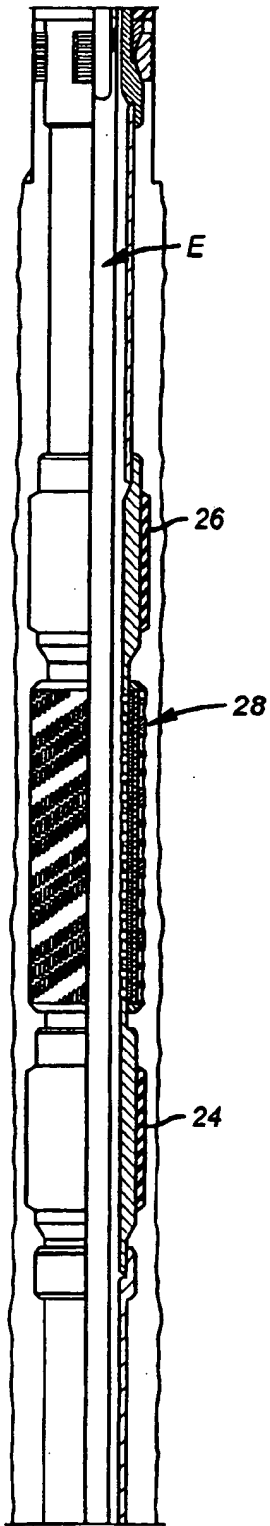

FIG. 2b

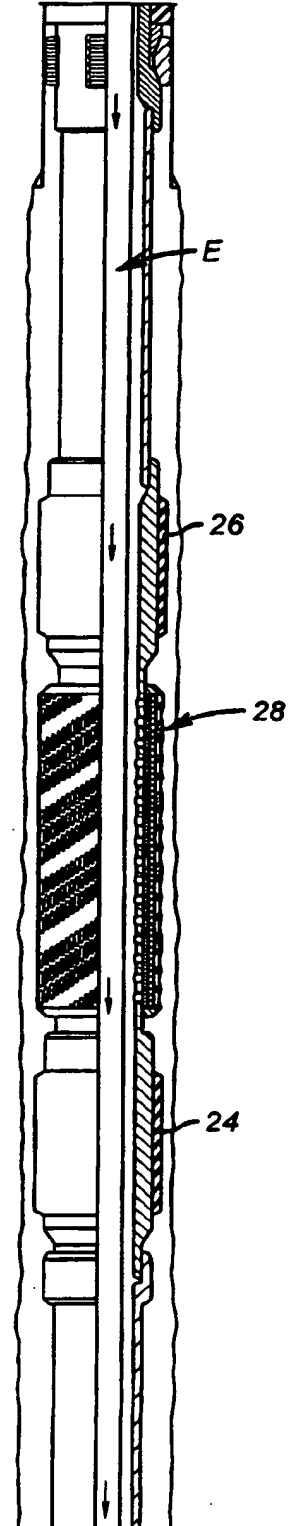

FIG. 3b

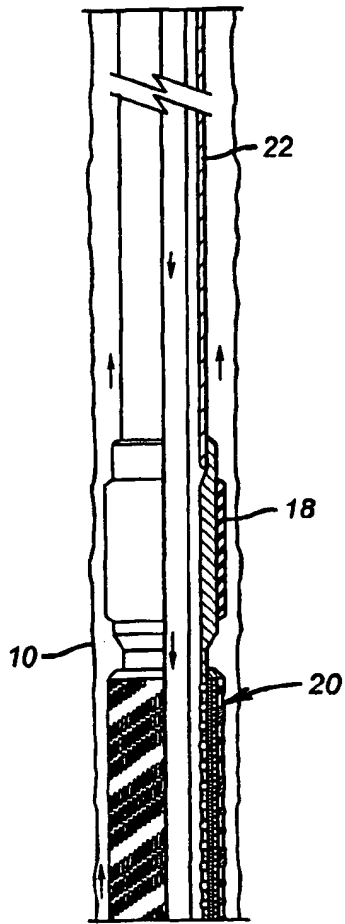

FIG. 1c

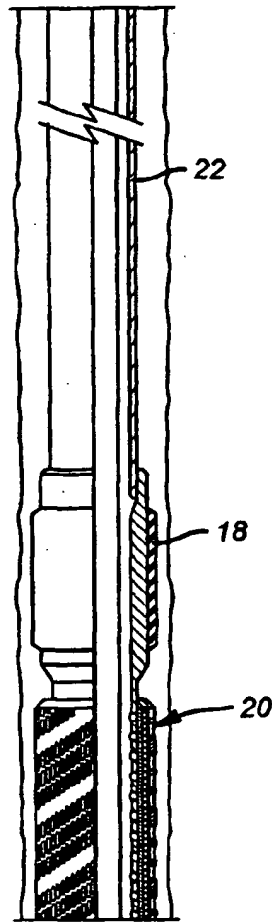

FIG. 2c

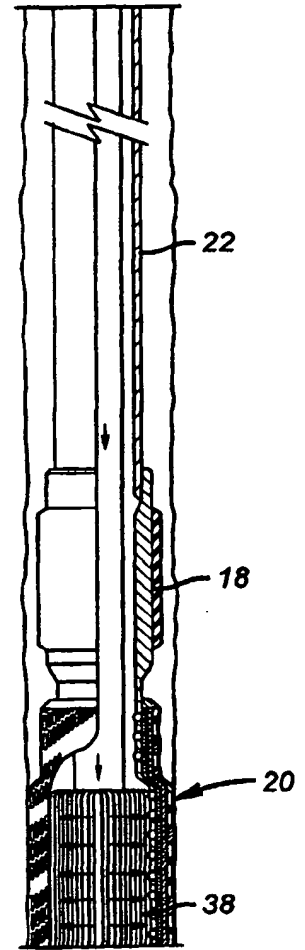

FIG. 3c

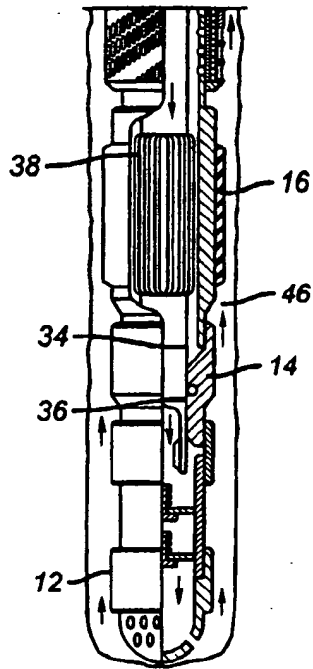

FIG. 1d

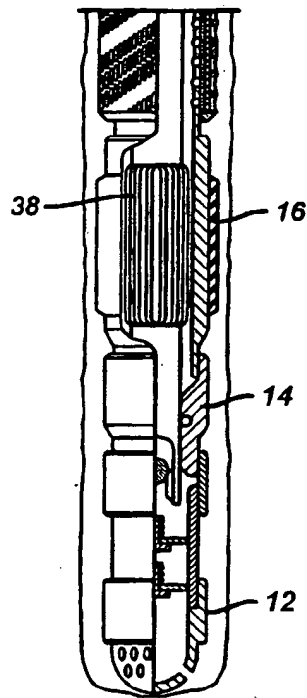

FIG. 2d

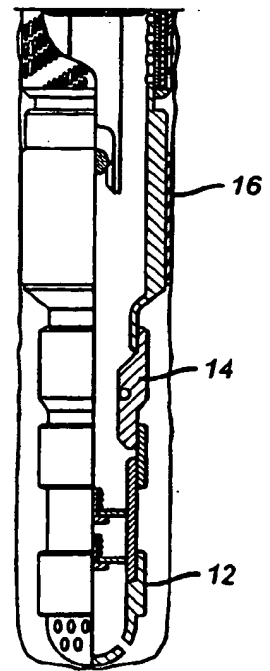

FIG. 3d

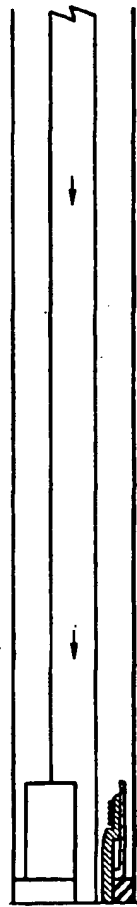

FIG. 4a

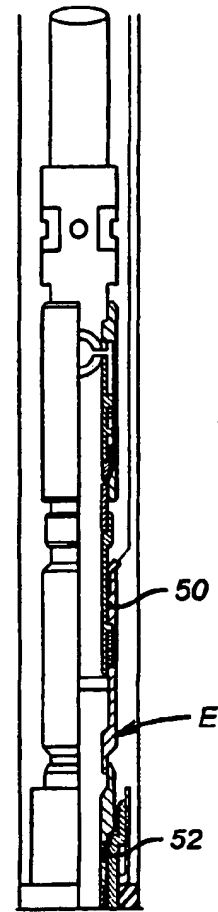

FIG. 5a

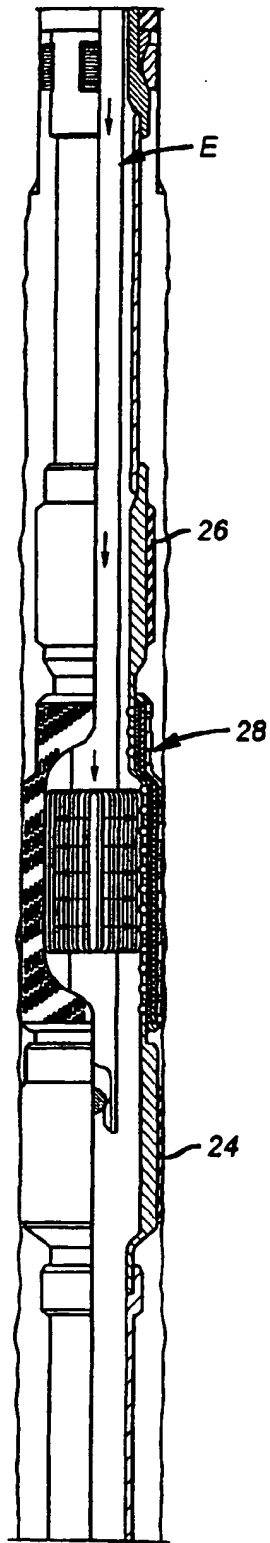

FIG. 4b

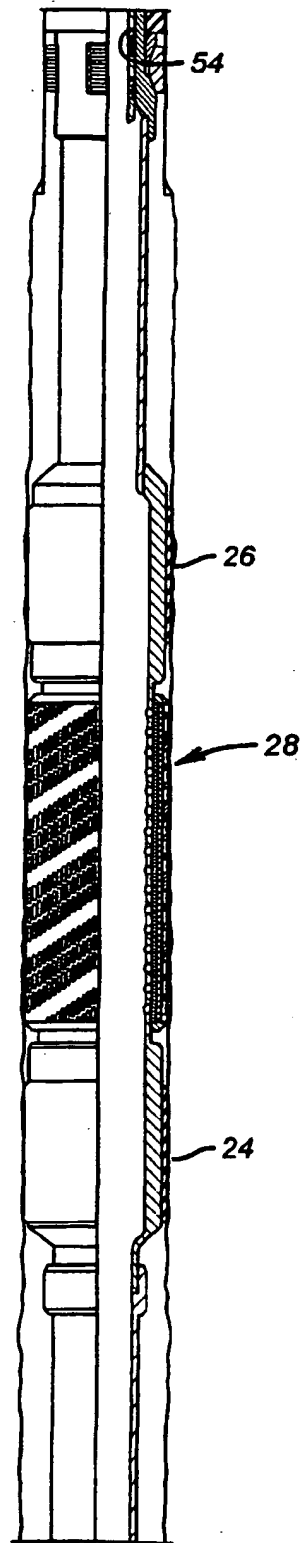

FIG. 5b

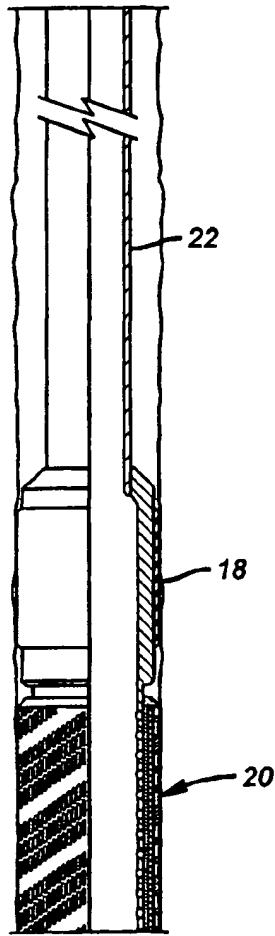

FIG. 4c

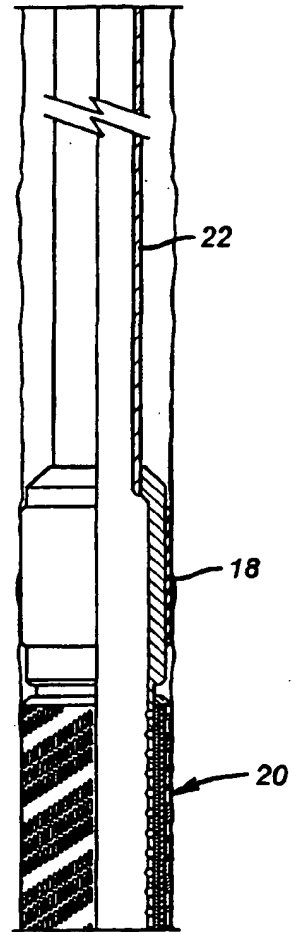

FIG. 5c

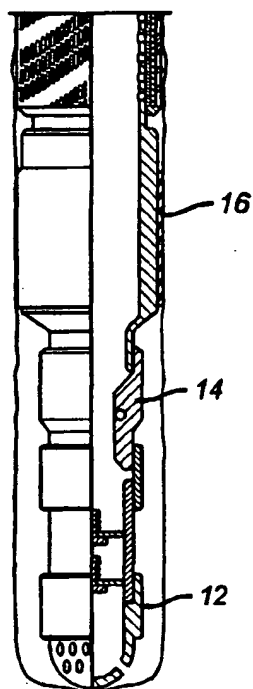

FIG. 4d

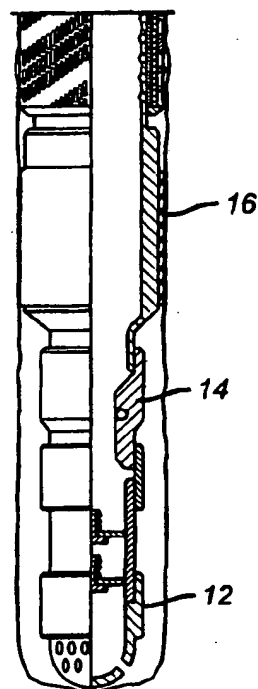

FIG. 5d

+

9/20

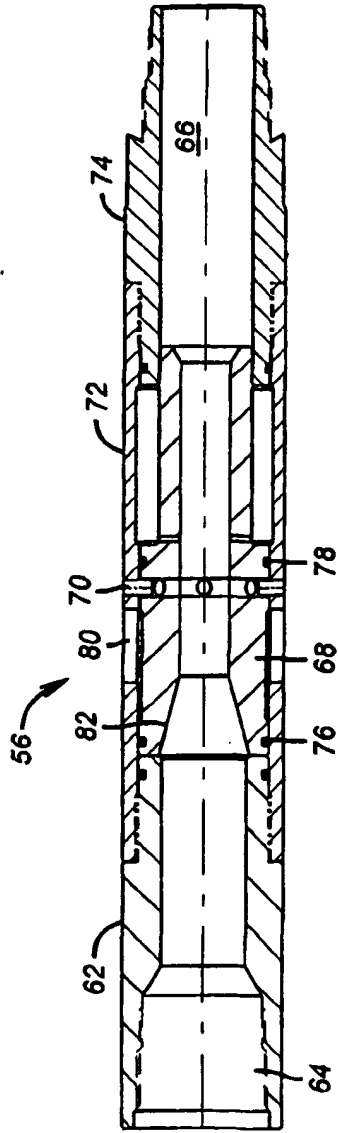

FIG. 6

42

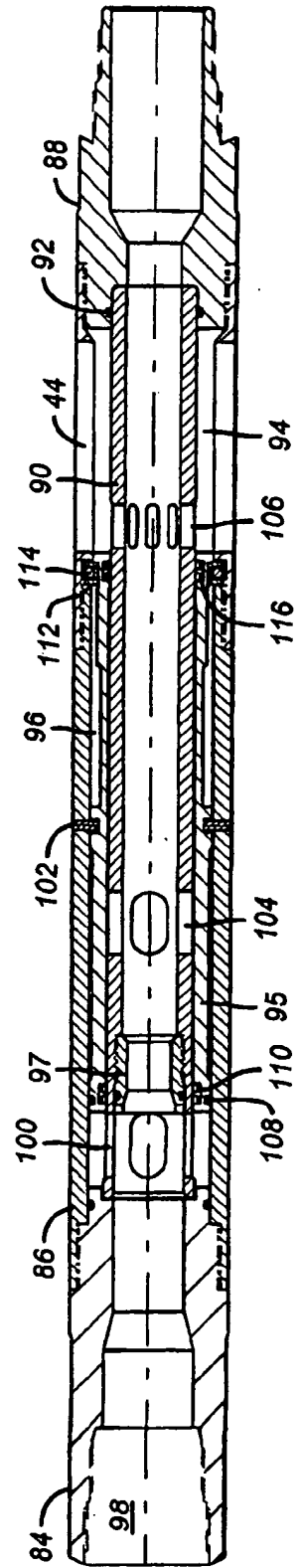

FIG. 7

+

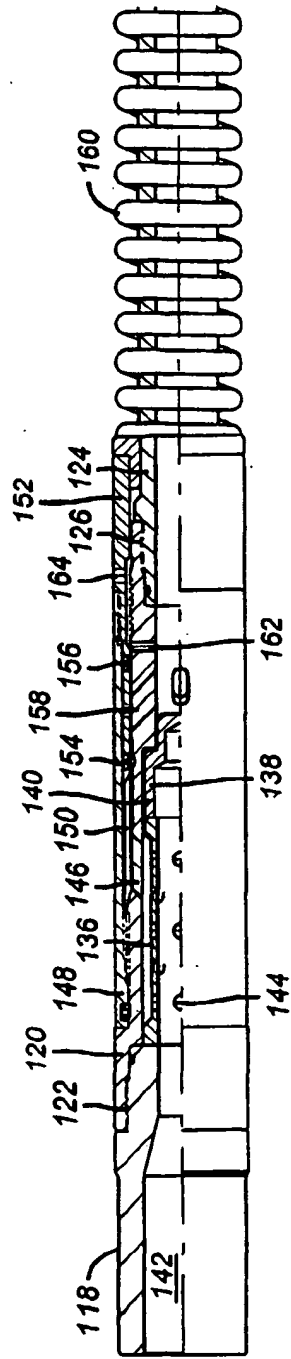

FIG. 8a

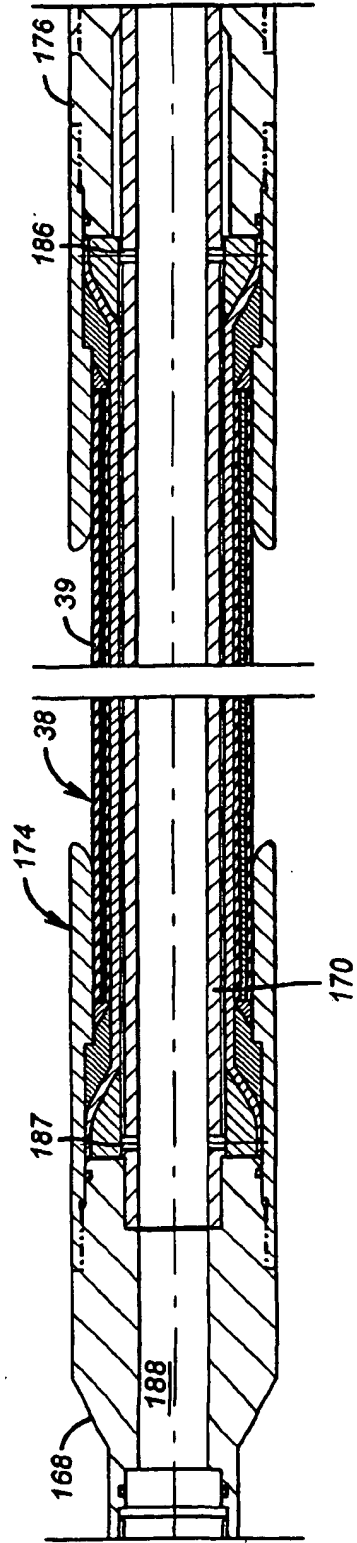

FIG. 9a

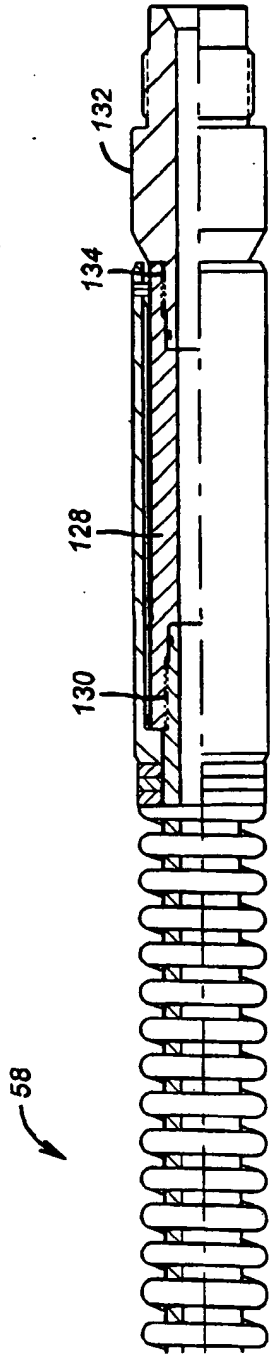

FIG. 8b

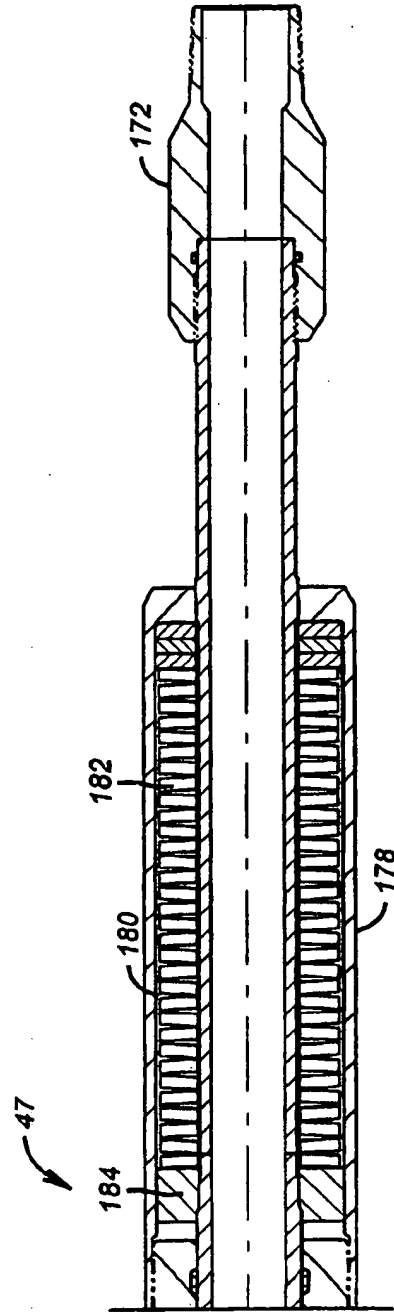

FIG. 9b

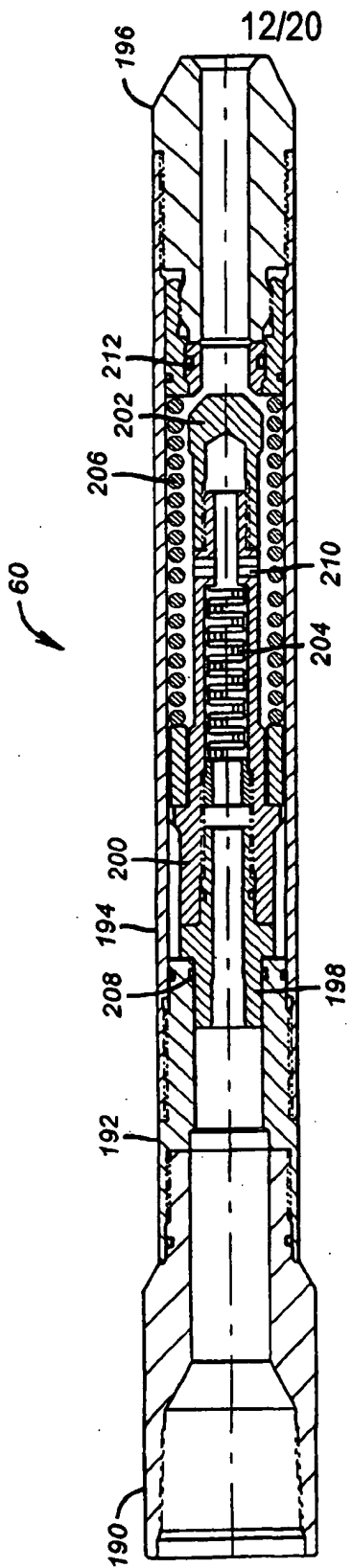

FIG. 10

+

+

+

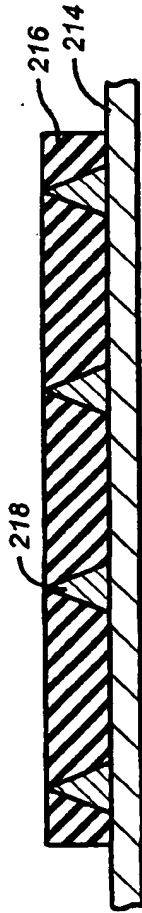

FIG. 11

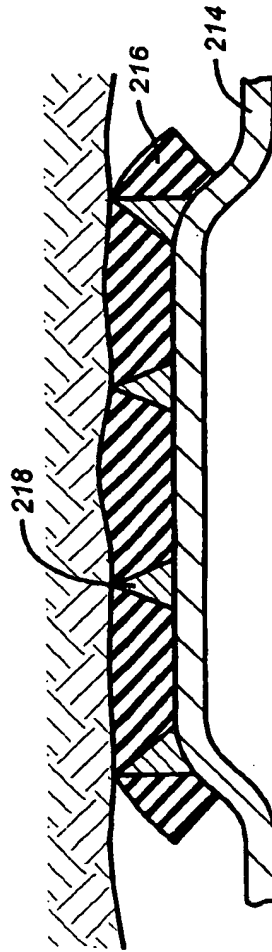

FIG. 12

+

+

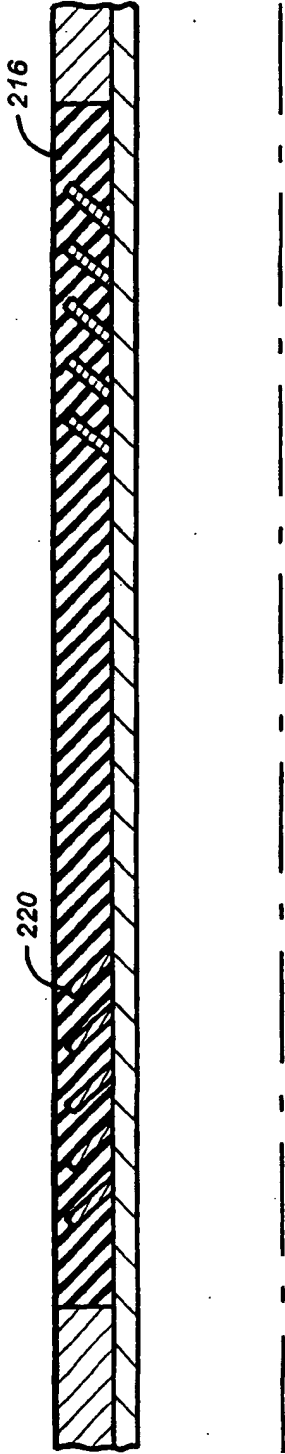

FIG. 13

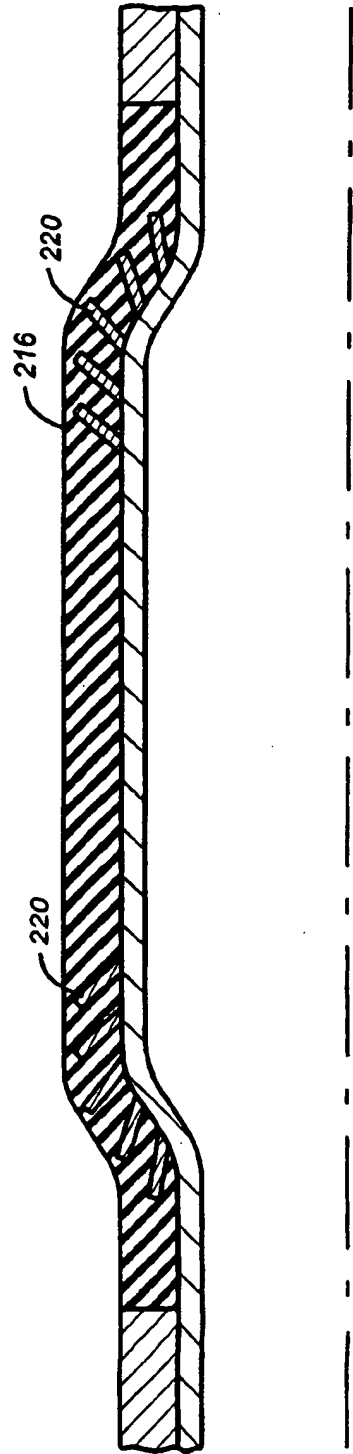

FIG. 14

+

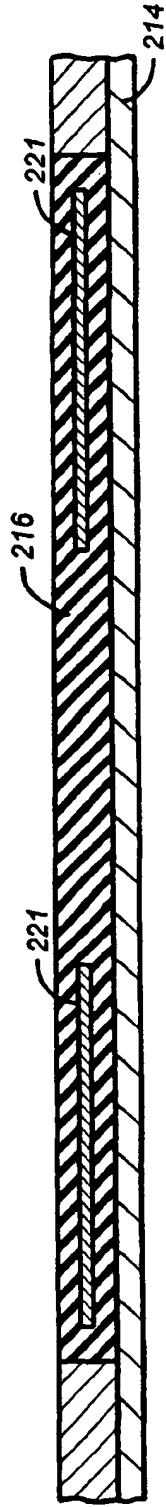

FIG. 15

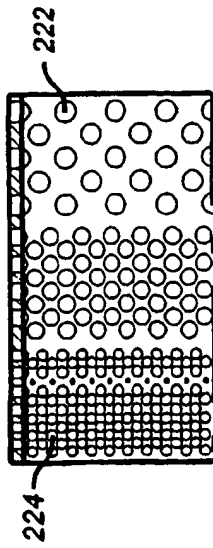

FIG. 16

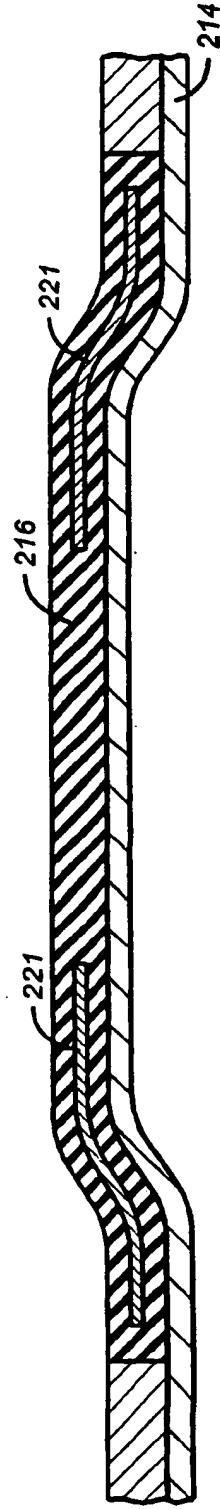

FIG. 17

+

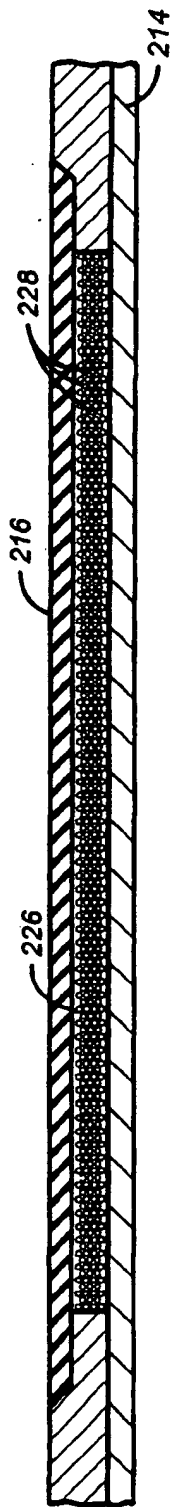

FIG. 18

16/20

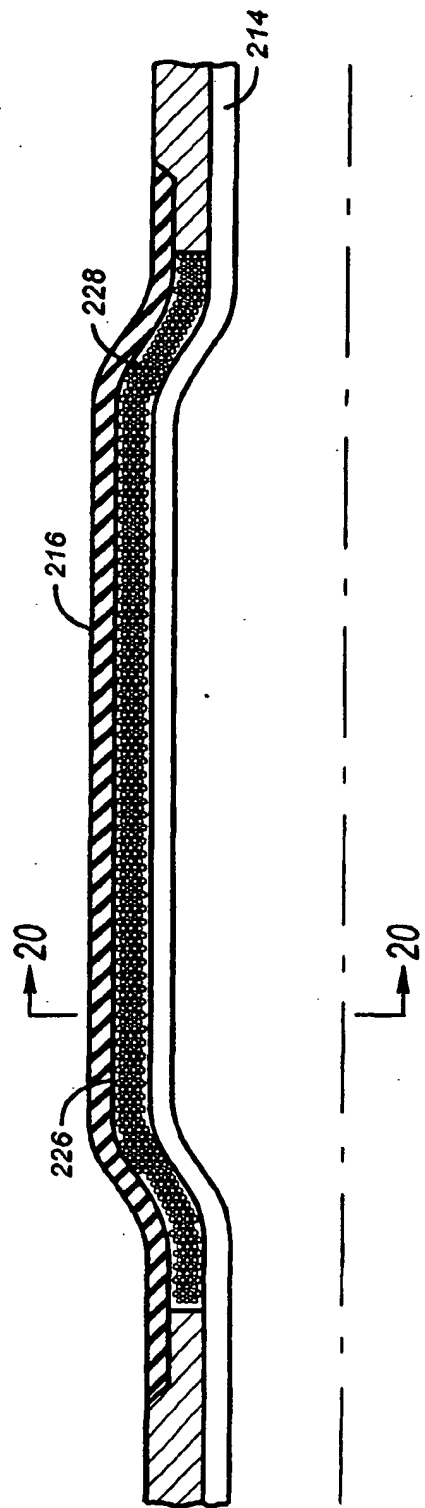

FIG. 19

+

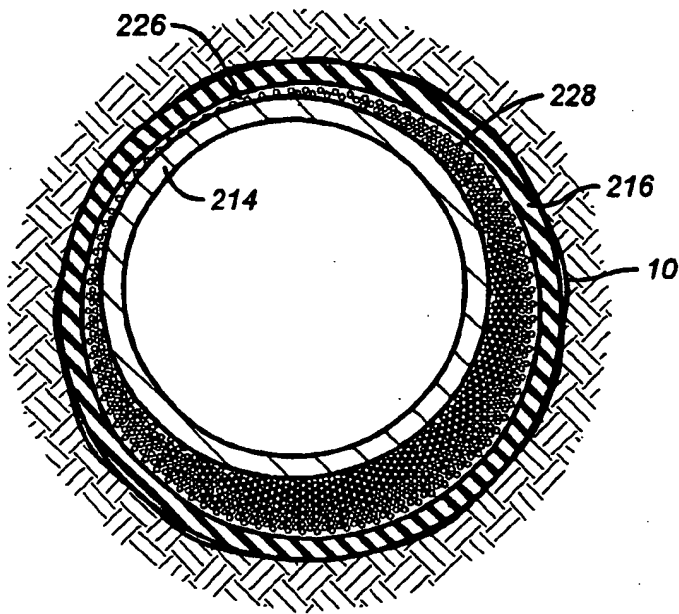

FIG. 20

+

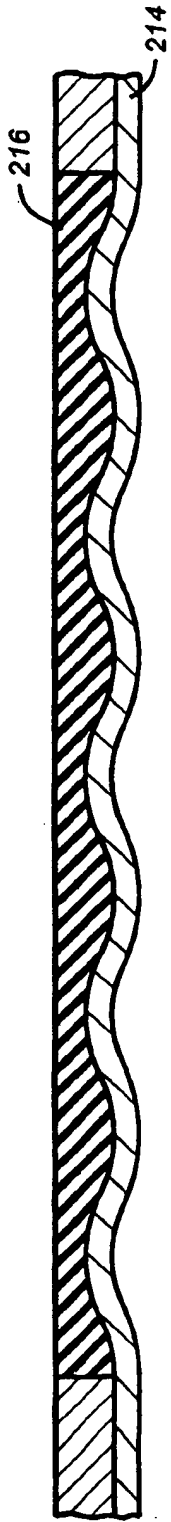

FIG. 21

18/20

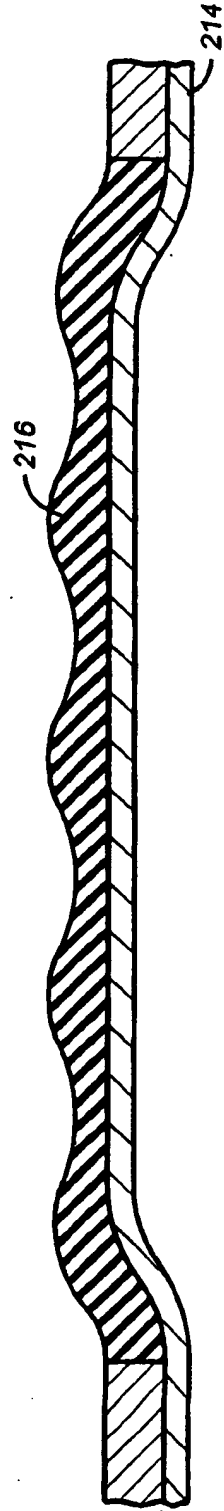

FIG. 22

18/20

+

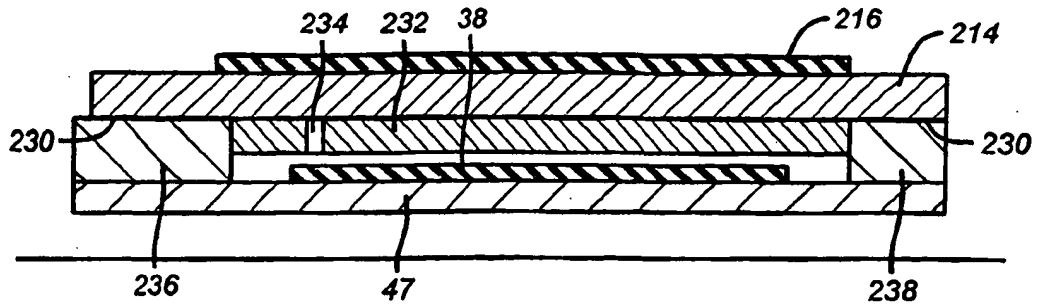

FIG. 23

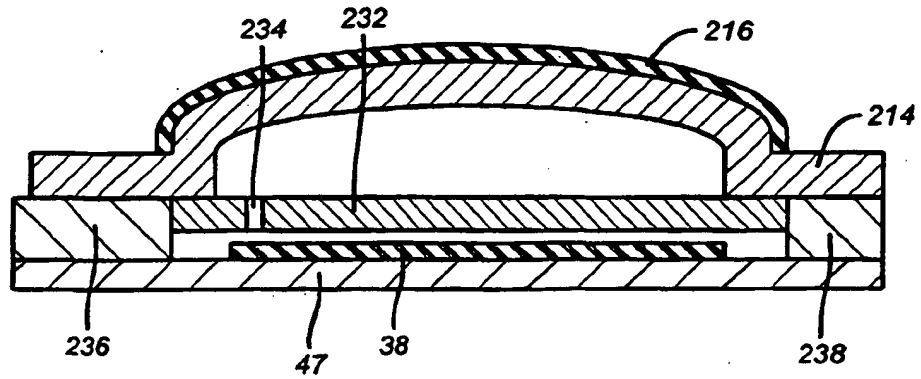

FIG. 24

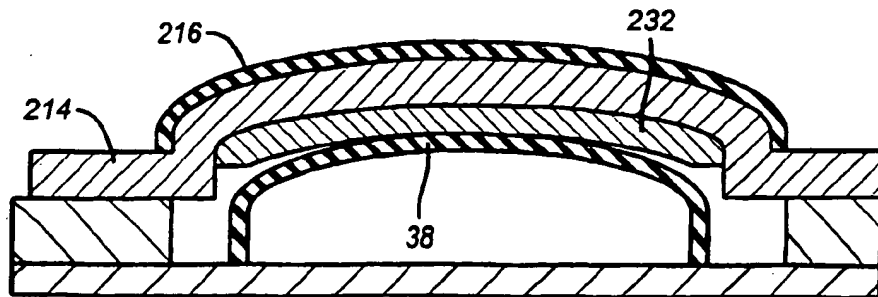

FIG. 25

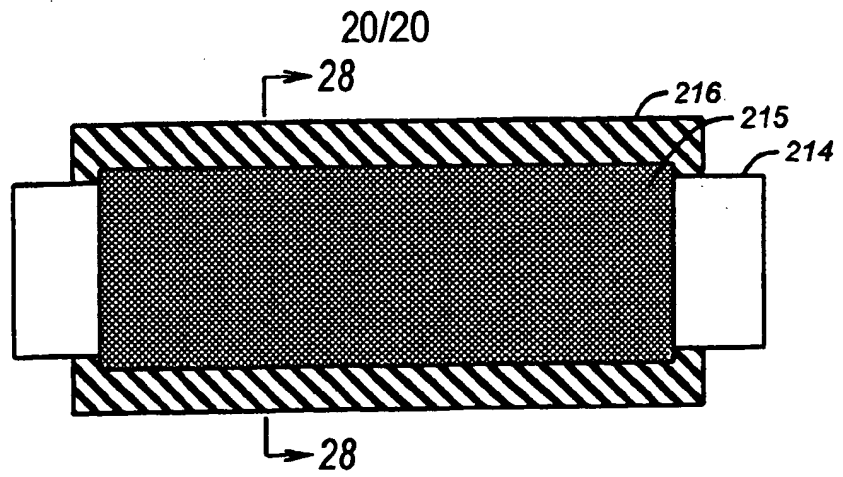

FIG. 26

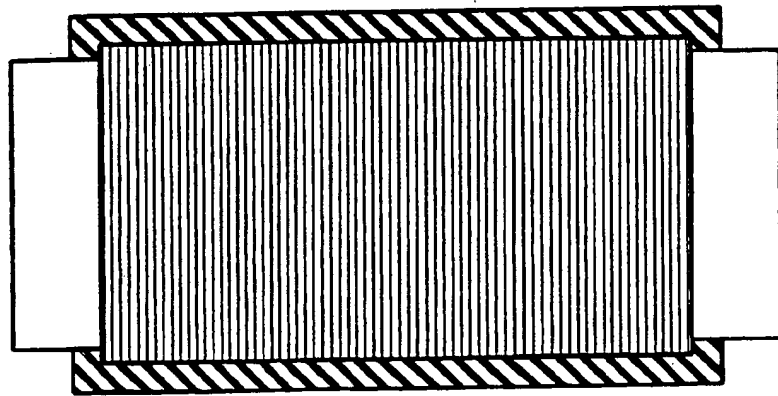

FIG. 27

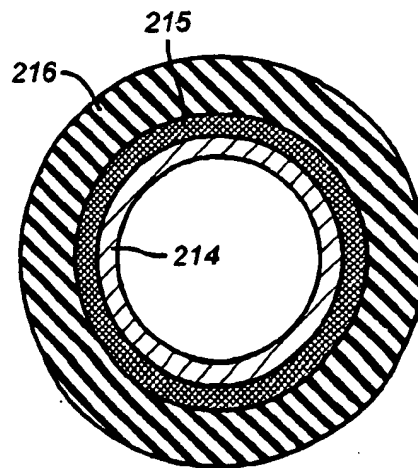

FIG. 28

1 **TITLE: EXPANDABLE PACKER ISOLATION SYSTEM**

2

3 **FIELD OF THE INVENTION**

4 The field of this invention is one-trip completion
5 systems, which allow for zone isolation and
6 production using a technique for expansion of
7 screens and isolators, preferably in open hole
8 completions.

9

10 **BACKGROUND OF THE INVENTION**

11 Typically zonal isolation is desirable in wells with
12 different pressure regimes, incompatible reservoir
13 fluids, and varying production life. The typical
14 solution to this issue in the past has been to
15 cement and perforate casing. Many applications
16 further required gravel packing adding an extra
17 measure of time and expense to the completion. The
18 cemented casing also required running cement bond
19 logs to insure the integrity of the cementing job.
20 It was not unusual for a procedure involving
21 cemented casing, gravel packing and zonal isolation
22 using packers to take 5-20 days per zone and cost as
23 much or over a million dollars a zone. Use of cement
24 in packers carried with it concerns of spills and
25 extra trips into the well. Frequently fracturing
26 techniques were employed to increase well
27 productivity but cost to complete was also
28 increased. Sand control techniques, seeking to
29 combine gravel packing and fracturing, also bring on
30 risks of unintended formation damage, which could
31 reduce productivity.

32

1 In open hole completions, gravel packing was
2 difficult to effectively accomplish although there
3 were fewer risks in horizontal pay zones. The
4 presence of shale impeded the gravel packing
5 operation. Proppant packs were used in open hole
6 completions, particularly for deviated or horizontal
7 open hole wells. Proppant packing involved running a
8 screen in the hole and pumping proppants outside of
9 it. Proppants such as gravel or ceramic beads were
10 effective to control cave-ins but still allowed
11 water or gas coning and breakthroughs. Proppant
12 packs have been used between activated isolation
13 devices such as external casing packers in
14 procedures that were complex, time consuming, and
15 risky. More recently, a new technique which is the
16 subject of a co-pending patent application also
17 assigned to Baker Hughes Incorporated a refined
18 technique has been developed wherein a proppant pack
19 is delivered on both sides of a non-activated
20 annular seal. In this technique the seal can
21 thereafter be activated against casing or open hole.
22 While this technique involved improved zonal
23 isolation, it was still costly and involved complex
24 delivery tools and techniques for the proppant.

25
26 Shell Oil Company has disclosed more recently,
27 techniques for expansion of slotted liners using
28 force driven cones. Screens have been mechanically
29 expanded, in an effort to eliminate gravel packing
30 in open hole completions. The use of cones to expand
31 slotted liners suffered from several weaknesses. The
32 structural strength of the screens or slotted liners

1 being expanded suffered as a tradeoff to allow the
2 necessary expansion desired. When placed in service
3 such structures could collapse at differential
4 pressures on expanded screens of as low as 2-300
5 pounds per square inch (PSI). Expansion techniques
6 suffered from other shortcomings such as the
7 potential for rupture of a tubular or screen upon
8 expansion. Additionally, where the well bore is
9 irregular the cone expander will not apply uniform
10 expansion force to compensate for void areas in the
11 well bore. This can detract from seal quality. Cone
12 expansion results in significant longitudinal
13 shrinkage, which potentially can misalign the screen
14 being expanded from the pay zone, if the initial
15 length is sufficiently long. Due to longitudinal
16 shrinkage, overstress can occur particularly when
17 expanding from bottom up. Cone expansions also
18 require high pulling forces in the order of 250,000
19 pounds. Slotted liner is also subject to relaxation
20 after expansion. Cone expansions can give irregular
21 fracturing effect, which varies with the borehole
22 size and formation characteristics.

23

24 Accordingly the present invention has as its main
25 objective the ability to replace traditional
26 cemented casing completion procedures. This is
27 accomplished by running isolators in pairs for each
28 zone to be produced with a screen in between. The
29 screen and isolators are delivered in a single trip
30 and expanded down hole using an inflatable device
31 to preferably expand the isolators. The screens can
32 also be similarly expanded using an inflatable tool

1 or by virtue of mechanical expansion, depending on
2 the application. Each zone can be isolated in a
3 single trip. The completion assembly and the
4 expansion tool can selectively be run in together or
5 on separate trips. These and other features of the
6 invention can be more readily understood by a review
7 of the description of the preferred embodiment,
8 which appears below.

9

10 **SUMMARY OF THE INVENTION**

11 A completion technique to replace cementing casing,
12 perforating, fracturing, and gravel packing with an
13 open hole completion is disclosed. Each zone to be
14 isolated by the completion assembly features a pair
15 of isolators, which are preferably tubular with a
16 sleeve of a sealing material such as an elastomer on
17 the outer surface. The screen is preferably made of
18 a weave in one or more layers with a protective
19 outer, and optionally an inner, jacket with
20 openings. The completion assembly can be lowered on
21 rigid or coiled tubing which, internally to the
22 completion assembly, includes the expansion
23 assembly. The expansion assembly is preferably an
24 inflatable design with features that provide limits
25 to the delivered expansion force and/or diameter. A
26 plurality of zones can be isolated in a single trip.

27

28 **DETAILED DESCRIPTION OF THE DRAWINGS**

29 Figures 1a-d, are a sectional elevation view of the
30 open hole completion assembly at the conclusion of
31 running in;

1 Figures 2a-d, are a sectional elevation view of the
2 open hole completion assembly showing the upper
3 optional packer in a set position;
4 Figures 3a-d, are a sectional elevation view of the
5 open hole completion assembly with a zone isolated
6 at its lower end;
7 Figures 4a-d, are a sectional elevation view of the
8 open hole completion assembly with a zone isolated
9 at its upper end;
10 Figures 5a-d, are a sectional elevation of the open
11 hole completion assembly in the production mode;
12 Figure 6 is a sectional elevation view of the
13 circulating valve of the expansion assembly;
14 Figure 7 is a sectional view elevation of the
15 inflation valve mounted below the circulating valve;
16 Figures 8a-b are a sectional elevation view of the
17 injection control valve mounted below the
18 circulating valve;
19 Figures 9a-b are a sectional elevation view of the
20 inflatable expansion tool mounted below the
21 injection control valve;
22 Figure 10 is a sectional elevation view of the drain
23 valve mounted below the inflatable expansion tool;
24 Figure 11 a detail of a first embodiment of the
25 sealing element on an isolator in the run in
26 position;
27 Figure 12 is the view of Fig. 11 in the set
28 position;
29 Figure 13 is a second alternative isolator seal in
30 the run in position;
31 Figure 14 is the view of Fig. 13 in the set
32 position;

1 Figure 15 is a third alternative isolator seal in
2 the run in position featuring end sleeves;
3 Figure 16 is a detail of an end sleeve shown in Fig.
4 15;
5 Figure 17 is the view of Fig. 15 in the set
6 position;
7 Figure 18 is a fourth alternative isolator seal
8 showing a filled cavity beneath it, in the run in
9 position;
10 Figure 19 is the view of Fig. 18 in the set
11 position;
12 Figure 20 is the view taken along line 20-20 shown
13 in Fig. 19;
14 Figure 21 illustrates a sectional elevation view of
15 an undulating seal on the isolator in the run in
16 position;
17 Figure 22 is the view of Fig. 21 in the set
18 position;
19 Figure 23 is another alternative isolator with a
20 wall re-enforcing feature shown in section during
21 run-in;
22 Figure 24 is the view of Fig. 23 after the mandrel
23 has been expanded;
24 Figure 25 is the view of Fig. 24 after expansion of
25 an insert sleeve with the bladder.
26 Figure 26 is a section view of an unexpanded
27 isolator showing travel limiting sleeve;
28 Figure 27 is the view of Fig. 26 after maximum
29 expansion of the isolator; and
30 Figure 28 is the view at line 28-28 of Fig. 26.
31
32 **DETAILED DESCRIPTION OF THE PREFERRED EMBODIMENT**

1 Referring to Figs. 1a-d, the completion assembly C
2 is illustrated in the run in position in well bore
3 10. At its lower end, as seen in Figs. 1d-5d are a
4 wash down shoe 12 and a seal sub 14 both of known
5 design and purpose. Working up-hole from seal sub 14
6 are a pair of isolators 16 and 18 which are spaced
7 apart to allow mounting a screen assembly 20 in
8 between. Further up-hole is a section of tubular 22
9 whose length is determined by the spacing of the
10 zones to be isolated in the well bore 10. Further
11 up-hole is another set of isolators 24 and 26 having
12 a screen assembly 28 in between. Optionally at the
13 top of the completion assembly C is a packer 30,
14 which is selectively settable against the well bore
15 10, as shown in Fig. 2a. Those skilled in the art
16 will appreciate that the completion assembly
17 described is for isolation of two distinct producing
18 zones. The completion assembly C can also be
19 configured for one zone or three or more zones by
20 repeating the pattern of a pair of isolators above
21 and below a screen for each zone.

22
23 The completion assembly C can be run in on an
24 expansion assembly E. Located on the expansion
25 assembly E is a setting tool 32 which supports the
26 packer 30 and the balance of the completion assembly
27 C for run in. Ultimately, the setting tool 32
28 actuates the packer 30 in a known manner. The
29 majority of the expansion assembly E is nested
30 within the completion assembly C for run in. At the
31 lower end 34 of the expansion assembly E, there is
32 engagement into a seal bore 36 located in seal sub

1 14. If this arrangement is used, circulation during
2 run in is possible as indicated by the arrows shown
3 in Figs. 1a-d.

4
5 The expansion assembly E shown in Figs. 1a-d through
6 5a-d is illustrated schematically featuring an
7 expanding bladder 38. The bladder 38 is shown above
8 the seal bore 36 in an embodiment where flow through
9 the expansion assembly E can exit its lower end 34.
10 In a known manner one or more balls can be dropped
11 to land below the bladder 38 so that it can be
12 selectively inflated and deflated at desired
13 locations. While this is one way to actuate the
14 bladder 38, the preferred technique is illustrated
15 in Figs. 6-10. Using the equipment shown in these
16 Figures, the placement of the seal bore 36 will need
17 to be above the bladder 38, as will be explained
18 below.

19
20 At this point, the overall process can be readily
21 understood. The completion assembly C is supported
22 off of the expansion assembly E for running in to
23 the well bore in tandem on rigid or coiled tubing
24 40. The setting tool 32 engages the packer 30 for
25 support. Circulation is possible during run in as
26 flow goes through the expansion assembly E and, in
27 the preferred embodiment shown in Fig. 7, exits
28 laterally through the inflation valve 42 at ports 44
29 which are disposed below a seal bore such as 36. It
30 should be noted that the inflation valve 42 (see
31 Fig. 7) is disposed above screen expansion tool 47
32 (see Figs. 9a-b), which comprises the bladder 38.

1 During run in, the bladder 38 is deflated and
2 circulation out of ports 44 goes around deflated
3 bladder 38 and out through wash down shoe 14, or an
4 equivalent lower outlet, and back to the surface
5 through annulus 46.

6 The packer 30 is set using the setting tool 32, in a
7 known manner which puts a longitudinal compressive
8 force on element 48 pushing it against the well bore
9 10, closing off annulus 46 (as shown in Fig. 2a).

10 The use of packer 30 is optional and other devices
11 can be used to initially secure the position of
12 completion assembly C prior to expansion, without
13 departing from the invention.

14 The expansion assembly is then actuated from the
15 surface to inflate bladder 38 so as to diametrically
16 expand the lowermost isolator 16, followed by screen
17 20, isolator 18, and, if present, isolator
18 24, followed by screen 28, and isolator 26. These
19 items can be expanded from bottom to top as
20 described or in a reverse order from top to bottom
21 or in any other desired sequence without departing
22 from the invention. The expansion technique involves
23 selective inflation and deflation of bladder 38
24 followed by a repositioning of the expansion
25 assembly E until all the desired zones are isolated
26 by expansion of a pair of isolators above and below
27 an expanded screen. The number of repositioning
28 steps is dependent on the length of bladder 38 and
29 the length and number of distinct isolation
30 assemblies for the respective zones to be isolated.
31 Fig.3c shows the lower screen 20 and the lowermost
32 isolator 16 already expanded. Fig. 4b shows the

1 upper screen 28 being expanded, while Figs. 5a-d
2 reveal the conclusion of expansion which results in
3 isolation of two zones, or stated differently, two
4 production locations in the well bore 10. This
5 Figure also illustrates that the expansion assembly
6 E has been removed and a production string 50 having
7 lower end seals 52 has been tagged into seal bore 54
8 in packer 30. It should be noted that tubular 22
9 has not been expanded as it lies between the zones
10 of interest that require isolation.

11 Now that the overall method has been described, the
12 various components, which make up the preferred
13 embodiment of the expansion assembly E, will be
14 further explained with reference to Figs. 6-10.
15 Going from up-hole to down hole the expansion
16 assembly E comprises: a circulating valve 56 (see
17 Fig. 6); an inflation valve 42 (see Fig. 7); an
18 injection control valve 58 (see Figs. 8a-b); an
19 inflatable expansion tool 47 (see Figs. 9a-b); and a
20 drain valve 60 (see Fig. 10).

21 The purpose of the circulating valve 56 is to serve
22 as a fluid conduit during the expansion and
23 deflation of the bladder 38. It comprises a top sub
24 62 having an inlet 64 leading to a through passage
25 66. A piston 68 is held in the position shown by one
26 or more shear pins 70. Housing 72 connects a
27 bottom sub 74 to the top sub 62. Seals 76 and 78
28 straddle opening 80 in housing 72 effectively
29 isolating opening 80 from passage 66. A ball seat 82
30 is located on piston 68 to eventually catch a ball
31 (not shown) to allow breaking of shear pins 70 and a
32 shifting of piston 68 to expose opening or openings

1 80. The main purpose of the circulating valve 56 is
2 to allow drainage of the string as the expansion
3 assembly E is finally removed from the well bore 10
4 at the conclusion of all the required expansions.
5 This avoids the need to lift a long fluid column
6 that would otherwise be trapped inside the tubing
7 40, during the trip out of the hole.

8 The next item, mounted just below the circulating
9 valve 56, is the inflation valve 42. It is
10 illustrated in the run in position. It has a top sub
11 84 connected to a dog housing 86, which is in turn
12 connected to a bottom sub 88. A body 90 is mounted
13 between the top sub 84 and the bottom sub 88 with
14 seal 92 disposed at the lower end of annular cavity
15 94. A piston 95, having a groove 96, is disposed in
16 annular cavity 94. Body 90 supports ball seat 97 in
17 passage 98. Body 90 has a lateral passage 100 to
18 provide fluid communication between passage 98 and
19 piston 95. A shear pin or pins 102 secure the
20 initial position of piston 95 to dog housing 86.
21 Body 90 also has lateral openings 104 and 106 while
22 dog housing 86 has a lateral opening 44 near opening
23 106. At the top of piston 95 are seals 108 and 110
24 to allow for pressure buildup above piston 95 in
25 passage 98 when a ball (not shown) is dropped onto
26 ball seat 97. Mounted to dog housing 86 are locking
27 dogs 112 which are biased into groove 96 when it
28 presents itself opposite dogs 112. Biasing is
29 provided by a band spring 114.

30 The operation of the inflation valve 42 can now be
31 understood. During run in, passage 98 is open down
32 to lateral opening 106. Since passage 98 is

1 initially obstructed in injection control valve 58,
2 for reasons to be later explained, flow into passage
3 98 exits the dog housing 86 through lateral
4 openings 106 (in body 90) and lateral opening 44 (in
5 dog housing 86). Since opening 44 is below a seal
6 bore (such as 36) mounted to the completion assembly
7 C flow from the surface will, on run in, go through
8 the circulating valve 56 and through passage 98 of
9 inflation valve 42 and finally exit at port 44 for
10 conclusion of the circulation loop to the surface
11 through annulus 46. Dropping a ball (not shown) onto
12 ball seat 97 allows pressure to build on top of
13 piston 95, which breaks shear pin 102 as piston 95
14 moves down. This downward movement allows flow to
15 bypass the now obstructed ball seat 97 by moving
16 seals 108 and 110 below lateral port 104. At the
17 same time, lateral port 44 is obstructed as seal 116
18 passes port 106 in body 90. The movement of piston
19 95 is locked as dogs 112 are biased by band spring
20 114 into groove 96. Pressure from the surface, at
21 this point, is directed into the injection control
22 valve 58.

23
24 The injection control valve 58 comprises a top sub
25 118 connected to a valve mandrel 120 at thread 122.
26 Valve mandrel 120 is connected to spring mandrel 124
27 at thread 126. Spring mandrel 124 is connected to
28 sleeve adapter 128 at thread 130. Sleeve adapter 128
29 is connected to bottom sub 132 at thread 134. Wedged
30 between valve mandrel 120 and top sub 118 are
31 perforated sleeve 136 and plug 138. Seal 140 is used
32 to seal plug 138 to valve mandrel 120. Flow entering

1 passage 142 from passage 98 in the inflation valve
2 42 passes through openings 144 in perforated sleeve
3 136 and through lateral passage 146 in valve mandrel
4 120. This happens because plug 138 obstructs passage
5 142 below openings 144. Piston 148 fits over valve
6 mandrel 120 to define an annular passage 150, the
7 bottom of which is defined by seal adapter 152,
8 which supports spaced seals 154 and 156. In the
9 initial position, seals 154 and 156 straddle passage
10 158 in valve mandrel 120. A pressure buildup in
11 annular passage 150 displaces piston 148 and moves
12 seal 154 past passage 158 to allow flow to bypass
13 plug 138 through a flow path which includes openings
14 144, passage 146, passage 158, and eventually out
15 bottom sub 132. At the same time spring 160 is
16 compressed by seal adapter 152, which moves in
17 tandem with piston 148. Seals 154 and 156 wind up
18 straddling passage 162 in valve mandrel 120. This
19 prevents escape of fluid out through passage 164 in
20 seal adapter 152. Accordingly, fluid flow initiated
21 from the surface will flow through injection control
22 valve 58 after sufficient pressure has displaced
23 piston 148. Such flow will proceed into inflatable
24 expansion tool 47. Upon removal of surface pressure,
25 spring 160 displaces seals 154 and 156 back above
26 passage 162 to allow pressure to be bled off through
27 passage 164 to allow bladder 38 to deflate, as will
28 be explained below.

29
30 Referring now to Figs. 9a-b, the structure and
31 operation of the inflatable expansion tool 47 will
32 now be described. A top sub 168 is connected to a

1 mandrel 170 and a bottom sub 172 is connected to the
2 lower end of the mandrel 170. Bladder 38 is retained
3 in a known manner to mandrel 170 by a fixed
4 connection at seal adapter 174 at its upper end and
5 by a movable seal adapter 176 at its lower end. Seal
6 adapter 176 is connected to spring housing 178 to
7 define a variable volume chamber 180 in which are
8 mounted a plurality of Belleville washers 182. A
9 stop ring 184 is mounted to mandrel 170 in a manner
10 where it is prevented from moving up-hole. Passages
11 186 and 187 communicate pressure in central passage
12 188 through the mandrel 170 and under bladder 38 to
13 inflate it. In response to pressure below the
14 bladder 38, there is up-hole longitudinal movement
15 of seal adapter 176 and spring housing 178. Since
16 stop ring 184 can't move in this direction, the
17 Belleville washers get compressed. Outward expansion
18 of bladder 38 can be stopped when all the Belleville
19 washers have been pressed flat. Other techniques for
20 limiting the expansion of bladder 38 will be
21 described below. What remains to be described is
22 the drain valve 60 shown in Fig. 10. It is this
23 valve that creates the back- pressure to allow
24 bladder 38 to expand.

25
26 The drain valve 60 has a top sub 190 connected to an
27 adapter 192, which is, in turn, connected to housing
28 194 followed, by a bottom sub 196. A piston 198 is
29 connected to a restrictor housing 200 followed by a
30 seal ring seat 202. Restrictor housing 200 supports
31 a restrictor 204. Spring 206 bears on bottom sub 196
32 and exerts an up-hole force on piston 198. Seal 208

1 forces flow through restrictor 204 producing back-
2 pressure, which drives the expansion of bladder 38.
3 Initially flow will proceed through restrictor 204
4 into passage 210 and around spring 206 and between
5 seal ring seat 202 and seal ring insert 212. This
6 flow situation will only continue until there is
7 contact between seal ring seat 202 and seal ring
8 insert 212. At that time flow from the surface stops
9 and applied pressure from surface pumps is applied
10 directly under bladder 38. One reason to cut the
11 flow from drain valve 60 is to prevent pressure
12 pumping into the formation below, which can have a
13 negative affect on subsequent production. When the
14 surface pumps are turned off, a gap reopens between
15 seal ring seat 202 and seal ring insert 212. Some
16 under bladder pressure can be relieved through this
17 gap. Most of the accumulated pressure will bleed off
18 through passage 164 in the injection control valve
19 58 (see Fig. 8a) in the manner previously described.

20
21 Those skilled in the art can now see how by
22 selective inflation and deflation of bladder 38 the
23 isolators and screens illustrated in Figs. 1a-d can
24 be expanded in any desired order.

25 Some of the features of the invention are the
26 various designs for the expandable isolator, such as
27 isolator 26, as illustrated in Figs. 11-22. It
28 should be noted that the isolator depicted in Figs.
29 1a-d is not an inflatable packer in the traditional
30 sense. Rather it is a tubular mandrel 214 surrounded
31 by a sealing sleeve 216 wherein inflatable, such as
32 bladder 38, or other devices are used to expand both

1 mandrel 214 and sleeve 216 together into the open
2 hole of well bore 10.

3 In the embodiments shown in Figs. 11 and 12 the
4 sleeve 216 is shown in rubber. There are
5 circumferential ribs 218 added to prevent rubber
6 migration or extrusion upon expansion. The expanded
7 view is illustrated in Fig. 12. In open hole
8 completions, the ribs 218 dig into the borehole
9 wall. This assures seal integrity against extrusion.
10 Ribs 218 can be directly attached to the mandrel 214
11 or they can be part of a sleeve, which is slipped
12 over mandrel 214 before the rubber is applied.
13 Direct connection of ribs 218 can cause locations of
14 high stress concentration, whereas a sleeve with
15 ribs 218 mounted to it reduces the stress
16 concentration effect. Ribs 218 can be applied in a
17 variety of patterns such as offset spirals. They can
18 be continuous or discontinuous and they can have
19 variable or constant cross-sectional shapes and
20 sizes.

21 A beneficial aspect of ribs 39 in bladder 38 (see
22 Fig. 9a) is that their presence helps to reduce
23 longitudinal shortening of mandrel 214 and sleeve
24 216 as they are diametrically expanded. Limiting
25 longitudinal shrinkage due to expansion is a
26 significant issue when expanding long segments
27 because a potential for a misalignment of the screen
28 and surrounding isolators from the zone of interest.
29 This effect can happen if there is significant
30 longitudinal shrinkage, which is a more likely
31 occurrence if there is a mechanical expansion with a
32 cone.

1
2 The expansion techniques can be a combination of an
3 inflatable for the isolators and a cone for
4 expansion of screens. This hybrid technique is most
5 useful for cone expanding long screen sections while
6 the isolators above and below are expanded with a
7 bladder. The isolators require a great deal of force
8 to assure seal integrity making the application of
9 inflatable technology most appropriate. The
10 inflation pressure for a bladder 38 disposed inside
11 an isolator can be monitored at the surface. The
12 characteristic pressure curve rises steeply until
13 the mandrel starts to yield, and then levels off
14 during the expansion process, and thereafter there
15 is a subsequent spike at the point of contact with
16 the formation or casing. It is not unusual to see
17 the plateau at about 6,000 PSI with a spike going as
18 high as 8500 PSI. Use of pressure intensifiers
19 adjacent the bladder 38, as a part of the expansion
20 assembly E, allows the up-hole equipment to operate
21 at lower pressures to keep down equipment costs. The
22 ability to monitor and control inflation pressure
23 can be a control technique to regulate the amount of
24 expansion in an effort to avoid mandrel failure or
25 overstressing the formation. Another monitoring
26 technique for real time expansion is to put strain
27 sensors in the isolator mandrels and use known
28 signal transmission techniques to communicate such
29 information to the surface in real time. Yet another
30 technique for limitation of expansion can be control
31 of the volume of incompressible fluid delivered
32 under the bladder 38. Another technique can be to

1 apply longitudinal corrugations to the mandrel 214,
2 such that the size it will expand to when rounded by
3 an inflatable is known.

4
5 Referring now to Figs. 13 and 14, another approach
6 to limiting extrusion of sealing sleeve 216 upon
7 expansion by a bladder 38, is to put reinforcing
8 ribs 220 in whole or in part at or near the upper
9 and/or lower ends of the sealing sleeve 216. Their
10 presence creates an increased force into the open
11 hole to reduce end extrusion, as shown in Fig. 14.

12
13 In Figs. 15-17, the anti-extrusion feature is a pair
14 of embedded rings 221 that run longitudinally in
15 sleeve 216. The stiffness of each ring 221 can be
16 varied along its length, from strongest at the ends
17 of sleeve 216 to weaker toward its middle. One way
18 to do this is to add bigger holes 222 closer to the
19 middle of sleeve 216 and smaller holes 224 nearer
20 the ends, as shown in Fig. 16. Another way is to
21 vary the thickness.

22
23 In Figs. 18-20, another variation is shown which
24 involves a void space 226 between the mandrel 214
25 and the sleeve 216. This space can be filled with a
26 deformable material, or a particulate material, such
27 as proppant, sand, glass balls or ceramic beads 228.
28 The beneficial features of this design can be seen
29 after there is expansion in an out of round open
30 hole, as shown in Fig. 20. Where there is a short
31 distance to expand to the nearby borehole wall,
32 contact of sleeve 216 occurs sooner. This causes a

1 displacement of the filler 228 so that the regions
2 with greater borehole voids can still be as tightly
3 sealed as the regions where contact is first made.
4 This configuration, in particular, as well as the
5 other designs for isolators discussed above offers
6 an advantage over mechanical expansion with a cone.
7 Cone expansion applies a uniform circumferential
8 expansion force regardless of the shape of the
9 borehole. The inflate technique conforms the applied
10 force to where the resistance appears. Expansions
11 that more closely conform to the contour of the well
12 bore can thus be accomplished. Use of the void 226
13 with filler 228 merely amplifies this inherent
14 advantage of expansion with a bladder 38. Those
15 skilled in the art will appreciate that the shorter
16 the bladder 38, the greater is the ability of the
17 isolator to be expanded in close conformity with the
18 borehole configuration. On the other hand, a
19 shorter bladder also requires more cycles for
20 expansion of a given length of isolator or screen.
21 Longer bladders not only make the expansion go
22 faster, but also allow for greater control of
23 longitudinal shrinkage. Here again, the ability to
24 control longitudinal shrinkage will have a tradeoff.
25 If the mandrel 214 is restrained from shrinking as
26 much longitudinally its wall thickness will decrease
27 on diametric expansion. Compensation for this
28 phenomenon by merely increasing the initial wall
29 thickness of the mandrel 214 creates the problem of
30 greatly increasing the required expansion pressure.
31

1 A solution is demonstrated in Figs. 23-25. In these
2 Figures, the mandrel 214 still has the sleeve 216.
3 Internally to mandrel 214 is a seal bore 230, which
4 can span the length of the sleeve 216. Within the
5 seal bore 230, the inflatable expansion tool 47 is
6 inserted. The inflatable expansion tool 47 has been
7 modified to have a bladder 38 and an insert sleeve
8 232 with a port 234 all mounted between two body
9 rings 236 and 238. Initially, as shown in Fig. 24,
10 fluid pressure expands the mandrel 214 against the
11 borehole through port 234. Then the bladder 38 is
12 expanded to push the sleeve 232 against the already
13 expanded mandrel 214 (see Fig. 25).

14
15 Yet another technique for improving the sealing of
16 an isolator is to take advantage of the greater
17 coefficient of thermal expansion in the sleeve 216
18 such as when it is made of rubber. If the rubber is
19 pre-cooled prior to running into the well bore it
20 will grow in size as it comes to equilibrium
21 temperature even after it has been inflatably
22 expanded. The subsequent expansion increases sealing
23 load. Thus rather than over-expanding the formation
24 in-order to store elastic energy in it, the use of a
25 mandrel 214 with a thin rubber sleeve 216 allows
26 storage of elastic strain in the rubber itself.
27 Although rubber has been mentioned for sleeve 216
28 other resilient materials compatible with down hole
29 temperatures, pressures and fluids can be used
30 without departing from the invention.

31

1 The screens, such as 28 can have a variety of
2 structures and can be a single or multi-layer
3 arrangement. In Fig.1b, the screen 28 is shown as a
4 sandwich of a 250-micron membrane 240 between inner
5 242 and outer 244 jackets. These jackets are
6 perforated or punched and the membrane itself can be
7 a plurality of layers joined to each other by
8 sintering or other joining techniques. The advantage
9 of the sandwich is to minimize relative expansion as
10 well as to protect the membrane 240.

11
12 Yet another isolator configuration is visible in
13 Figs. 21-22. Here the mandrel 214 has a wavy
14 configuration one embodiment of which is a
15 circumferential ribbed appearance. The sleeve 216 is
16 applied to have a cylindrical exterior surface.
17 After expansion, as seen in Fig. 22, the mandrel 214
18 becomes cylindrically shaped while the sleeve takes
19 on a wavy exterior shape with peaks where the
20 mandrel 214 had valleys, in its pre-expanded state.

21
22 Yet another issue resolved by the present invention
23 is how to limit expansion of the isolators in a
24 radial direction. Unrestrained growth can result in
25 rupture if the elongation limits of the mandrel 214
26 are exceeded. Additionally, excessive loads on the
27 formation can fracture it excessively adjacent the
28 isolator. Expansion limiting devices can be applied
29 to the isolator itself or to the fluid expansion
30 tool used to increase its diameter. In one example,
31 the mandrel 214 is wrapped in a sleeve 215 made of a
32 biaxial metal weave before the rubber is applied.

1 This material is frequently used as an outer jacket
2 for high- pressure industrial hose. It allows a
3 limited amount of diametric expansion until the
4 weave "locks up" at which time further expansion is
5 severely limited in the absence of a dramatic
6 increase in applied force. This condition can be
7 monitored from the surface so as to avoid over-
8 expansion of the isolator.

9
10 As an expanding-mandrel packer is radially expanded
11 outwards it is desirable to have a mechanism in
12 place to limit the radial growth of the packer. If
13 the packer is allowed to expand without restraint of
14 some kind it will ultimately rupture once the
15 elongation limit of the mandrel material is
16 exceeded. Also, if the packer is allowed to place
17 an excessive load against an open hole formation
18 wall the formation may be damaged and caused to
19 fracture adjacent to the packer. There needs to be
20 an expansion limiting mechanism in either the
21 packer, such as isolator 16, or expansion device,
22 such as expansion assembly E.

23
24 If the expanding-mandrel packer is being expanded
25 using an inflatable packer (i.e. using hydraulic
26 pressure), once the yield point of the material is
27 exceeded and the mandrel deforms plastically,
28 pressure indications of the amount of radial
29 expansion is impossible. Therefore, it is desirable
30 that once a pre-determined level of expansion is
31 obtained there is a pressure indication that would
32 indicate the packer is at its maximum design limit.

1 An increase in applied pressure would be obtained if
2 at some point the packer is subjected to an
3 increased mechanical force opposing additional
4 expansion.

5
6 The expansion of the packer may be limited by
7 wrapping a bi-axial metal weave sleeve over the
8 mandrel (see Fig. 26) prior to adding the sealing
9 medium 216 (i.e. rubber). The bi-axial sleeve 215
10 will grow circumferentially as the packer mandrel is
11 expanded, however at a pre-determined diameter the
12 bi-axial sleeve will "lock-up" (see Fig. 27),
13 preventing any additional radial expansion of the
14 mandrel without a significant increase in applied
15 radial load from the expansion device. This could
16 give an indication at the surface that the limiting
17 diameter of the packer has been reached, and further
18 expansion is ceased.

19
20 The bi-axial mesh sleeve 215 would be fabricated in
21 a tubular shape, and would be installed over the
22 expanding-mandrel 214 during assembly of the packer.
23 The mesh sleeve 215 would be in the un-expanded
24 condition at this time. A rubber sealing cover 216
25 would then be applied over the bi-axial sleeve 215
26 to serve as the sealing component as the packer is
27 expanded radially against the open-hole or casing.
28 The assembled packer cross section is shown in Fig.
29 28.

30
31 As the packer is expanded in the borehole, the bi-
32 axial mesh sleeve 215 expands circumferentially

1 along with the packer mandrel 214. The rubber cover
2 216 is also expanding at this time. Once a pre-
3 determined amount of expansion is obtained however
4 the weaved metal fibers in the bi-axial sleeve will
5 reach a configuration where further expansion is not
6 possible, without breaking the fibers in the mesh.
7 This will result in additional resistance to radial
8 expansion, which will be detected by an increase in
9 applied pressure required for additional expansion.
10 At this point attempts at further expansion is
11 ceased.

12
13 Fig. 27 shows the condition of the packer after
14 reaching the expansion limit of the packer, as
15 dictated by the maximum diametrical growth limit of
16 the bi-axial mesh sleeve 215. The fiber orientation
17 in the mesh sleeve is more in a perpendicular
18 orientation to the long axis of the packer than
19 before expansion was started. The amount of
20 expansion possible in these mesh sleeves is dictated
21 by the wrapping pattern used, and can be varied to
22 allow various expansion potentials.

23
24 The amount of expansion of bladder 38 can also be
25 limited by regulation of volume delivered to it by
26 measuring the flow going in or by delivering fluid
27 from a reservoir having a known volume. Typically
28 the isolators and screens of the present invention
29 will have to be expanded up to 25%, or more, to
30 reach the borehole. This requires materials with
31 superior ductility and toughness. Some acceptable
32 materials are austenitic stainless steels, such as

1 304L or 316L, super austenitic stainless steel (Alloy
2 28), and nickel based alloys (Inconel 825). As much
3 as a 45% elongation can be achieved by using these
4 materials in their fully annealed state. These
5 materials have superior corrosion resistance
6 particularly in chlorides or in sour gas service,
7 although some of the materials perform better than
8 others. Inconel 825 is very expensive which may rule
9 it out for long intervals. In vertical wells with
10 short zones this cost will not normally be an issue.

11

12 The sequence of expansion can also have an effect on
13 the overall system performance of the isolators. A
14 desirable sequence can begin with an upper isolator
15 followed by a screen expansion followed by expansion
16 of the lower isolator. Simultaneous expansion of the
17 isolators and screen should be avoided because of
18 the potentially different pressure responses, which,
19 in turn, can cause either under or over expansion of
20 the isolators, which, in turn, can cause inadequate
21 sealing or formation fracturing.

22

23 When an isolator, such as 16, is expanded, the
24 sealing integrity can be checked. This can be
25 accomplished using the expansion assembly E
26 illustrated in Figs. 6-10. After expansion of the
27 bladder 38, which sets isolator 16, the bladder 38
28 is allowed to deflate by removal of pressure from
29 the surface. Thereafter, flow from the surface is
30 resumed with bladder 38 still in position inside the
31 now expanded isolator 16. The injection control
32 valve 58 is opened by flow through it, which

1 ultimately exits through the drain valve 60. Due to
2 creation of backpressure by virtue of restrictor 204
3 (see Fig. 10) the bladder re-inflates inside the
4 expanded mandrel 214 of the isolator 16. A seal is
5 created between the completion assembly C and the
6 expansion assembly E. Since there is an exit point
7 at wash down shoe 14 and the isolator 16 is already
8 expanded against the well bore 10, applied pressure
9 from the surface will go back up the annulus 46
10 until it encounters the sealing sleeve 216, which is
11 now firmly engaging the bore hole wall 10. The
12 annulus 46 is monitored at the surface to see if any
13 returns arrive. Absence of returns indicates the
14 seal of isolator 16 is holding. It should be noted
15 that conducting this test puts pressure on the
16 formation for a brief period. It should also be
17 noted that the other isolators could be checked for
18 leakage in a similar manner. For example, isolator
19 18 can be checked with bladder 38 re-inflated and
20 flow through the expansion assembly E, which exits
21 through screen 20 and exerts pressure against a
22 sealing sleeve 216 of isolator 18.

23
24 As previously mentioned, it may be desirable to
25 combine the inflatable technique with a mechanical
26 expansion technique using a cone expander. The
27 driven cone technique may turn out to be more useful
28 in expanding the screen, since substantially less
29 force is required. Cone expansion is a continuous
30 process and can be accomplished much faster for the
31 screens, which are typically considerably longer
32 than the isolators. When it comes to the isolators,

1 the cone expansion technique has some serious
2 drawbacks. Since the isolators must be expanded in
3 open hole or casing in order to obtain a seal with a
4 force substantial enough for sealing, greater
5 certainty is required that such a seal has been
6 accomplished than can be afforded with cone
7 expansion techniques. In open hole applications, the
8 exact diameter of the hole is unknown due to
9 washouts, drill pipe wear of the borehole, and other
10 reasons. In cased hole applications, there is the
11 issue of manufacturing tolerances in the casing. If
12 the casing is slightly oversized, there will be
13 insufficient sealing using a cone of a fixed
14 dimension. There may be contact by the sealing
15 sleeve 216 but with insufficient force to hold back
16 the expected differential pressures. On the other
17 hand, if the casing is undersized, the isolator may
18 provide an adequate seal but the amount of realized
19 expansion may be too small to allow the cone driver
20 to pass through. If driving from bottom to top there
21 will be a solid lockup, which prevents removal of
22 the cone driver from the well. If driving from top
23 to bottom the isolator will not be able to expand
24 over its entire length. A solution can be the use of
25 the expansion assembly E for the isolator expansion
26 in combination with a cone expansion assembly for
27 the screens. These two expansion assemblies can be
28 run in separate trips or can be combined together in
29 a single assembly, which preferably is run into the
30 borehole together with the completion assembly C.
31

1 It is known that drilling fluids can cause a
2 drilling-induced damage zone immediately around the
3 well bore 10. Depending on factors such as formation
4 mechanical properties and residual stresses radial
5 fractures can be extended as much as two feet into
6 the formation to bypass the drilling-induced damage
7 zone. This can be accomplished by over expanding the
8 screens as they contact the well bore. A stable
9 fracture presents little or no danger of migration
10 into the zone sealed by the packers. Thus, for
11 example in an eight inch well bore an expansion
12 pressure of about 2500 PSI yields a fracture radius
13 of about .5 feet, while a pressure of 7600PSI causes
14 a 1 foot radius fracture. Because of the large
15 friction existing between the screen and the well
16 bore wall, multiple radial fractures may be induced
17 in different directions, not necessarily aligned
18 with the maximum horizontal stress direction.
19 Increased fracture density improves well bore
20 productivity.

21
22 Those skilled in the art will appreciate that the
23 techniques described above can result in a savings
24 in time and expense in the order of 75% when
25 compared to traditional techniques of cementing and
26 perforating casing coupled with traditional gravel
27 packing operations. The system is versatile and can
28 be accomplished while running coiled tubing because
29 the expansion technique is not dependent on work
30 string manipulation as may be needed for a cone
31 expansion using pushing or pulling on the work
32 string. Expansion techniques can be combined and

1 can include roller expansion as well as cone or an
2 inflatable or combinations. The expansion assembly E
3 can expand both the isolators and the screens.
4 Another expansion device that can be used is a
5 swedge. The preferred direction of expansion is
6 down hole starting from the packer 30 or any other
7 sealing or anchoring device, which can be used in
8 its place. The inflatable technique acts to limit
9 axial contraction when compared to other methods of
10 expansion due to the axial contact constraint
11 between the inflatable and isolator or screen during
12 the expansion process. The sealing sleeve 216 can be
13 rubber or other materials that are compatible with
14 conditions down hole and exhibit the requisite
15 resiliency to provide an effective seal at each
16 isolator. The formulation of the sleeve can vary
17 along its length or in a radial direction in an
18 effort to obtain the requisite internal pressure for
19 sealing while at the same time limiting extrusion.
20 Real time feedback can be incorporated into the
21 expansion procedure to insure sufficient expansion
22 force and to prevent over-stressing. Stress can be
23 sensed during expansion and reported to the surface
24 as the bladder 38 expands. The delivered volume to
25 the bladder 38 can be controlled or the flow into it
26 can be measured. The formation can be locally
27 fractured by screen expansion to compensate for
28 drilling fluid, which can contaminate the borehole
29 wall. Using the isolators with tubular mandrels 214
30 a far greater strength is realized than prior
31 techniques, which required liners to be slotted to
32 reduce expansion force while sacrificing collapse

1 resistance. The sandwich screens of the present
2 invention can withstand differential pressures of 2-
3 3000 PSI as compared to other structures such as
4 those expanded by rollers where resistance to
5 collapse is only in the order of 2-300 PSI.

6 In another expansion technique, the mandrel 214 can
7 be made from material which, when subjected to
8 electrical energy increases in dimension to force
9 the sealing sleeve 216 into sealing contact with the
10 borehole.

11
12 The use of an inflatable technique to expand the
13 isolators and screens allows flexibility in the
14 direction of expansion i.e. either up-hole or down-
15 hole. It further allows selective expansion of the
16 screens, using a variety of techniques, followed by
17 subsequent isolator expansion by the preferred use
18 of the expansion assembly E.

19
20 The length of the inflatable is inversely related to
21 its sensitivity to borehole variation and is
22 directly related to the speed with which the
23 isolator is expanded. The screens can be expanded
24 with bladder 38 to achieve localized or more
25 extensive formation fracturing. Overall, higher
26 forces for expansion can be delivered using the
27 expansion assembly E than other expansion
28 techniques, such as cone expansions. The inflatable
29 technique can vary the force applied to create
30 uniformity in fracture effect when used in a well
31 bore with differing hardness or shape variations.

1 The inflatable expansion can be accomplished using a
2 down hole piston that is weight set or actuated by
3 an applied force through the work string. If
4 pressure is used to actuate a down hole piston, a
5 pressure intensifier can be fitted adjacent the
6 piston to avoid making the entire work string handle
7 the higher piston actuation pressures.

8

9 The isolators can have constant or variable wall
10 thickness and can be cylindrically shaped or
11 longitudinally corrugated.

12

13 The above description is illustrative of the
14 preferred embodiment and the full scope of the
15 invention can be determined from the claims, which
16 appear below.

1 Claims:

2

3 1. A well completion method for isolating at least
4 one zone, comprising:

5 running into the wellbore a string with at
6 least one isolator in conjunction with a tool which
7 allows flow from the surrounding formation into the
8 string;

9 expanding said isolator and said tool in said
10 wellbore.

11 2. The method of claim 1, comprising:

12 performing said expanding of said isolator and
13 said tool in a single trip into the wellbore.

14 3. The method of claim 1, comprising:

15 running in an anchor with said string;
16 setting the anchor before said expanding; and
17 releasing the string from the anchor before
18 said expanding.

19 4. The method of claim 1, comprising:

20 running in an expansion assembly comprising an
21 inflatable with said string; and
22 expanding said at least one isolator at least
23 in part with said inflatable.

24 5. The method of claim 4, comprising:

25 selectively deflating and moving said
26 inflatable for repositioning;

27 continuing expansion of said at least one
28 isolator or tool by re-inflating said inflatable
29 after said repositioning.

30 6. The method of claim 1, comprising:

1 forming said at least one isolator from an un-
2 perforated mandrel covered by a resilient sealing
3 sleeve.

4 7. The method of claim 6, comprising:
5 expanding said mandrel from its original size;
6 and
7 using at least a partially annealed material for
8 said mandrel.

9 8. The method of claim 6, comprising:
10 limiting the amount of expansion with a device
11 fitted to said mandrel.

12 9. The method of claim 8, comprising:
13 using a woven sleeve around said mandrel that
14 locks up after a predetermined amount of expansion
15 of said mandrel as said device.

16 10. The method of claim 8, comprising:
17 using a strain sensor as said device;
18 transmitting, in real time, the sensed strain
19 to the surface; and
20 determining the amount of expansion from said
21 sensed strain.

22 11. The method of claim 6, comprising:
23 providing radially extending members from said
24 mandrel into said resilient sealing sleeve to resist
25 extrusion of said resilient sleeve after expansion
26 of said mandrel.

27 12. The method of claim 6, comprising:
28 providing an embedded ring located adjacent at
29 least one end of said resilient sleeve to resist
30 extrusion of said sleeve after expansion of said
31 mandrel.

32 13. The method of claim 12, comprising:

1 varying the stiffness of said ring along its
2 length.

3 14. The method of claim 6, comprising:

4 providing exterior undulations on said mandrel;
5 providing a cylindrically shaped outer surface
6 on said resilient sleeve;

7 converting said cylindrical shape of the outer
8 surface of said resilient sleeve to an undulating
9 shape upon expansion of said mandrel.

10 15. The method of claim 6, comprising:

11 providing a void between said mandrel and said
12 resilient sealing sleeve;

13 placing a deformable material or a particulate
14 material in said void;

15 using said deformable material or said
16 particulate material to aid said resilient sleeve
17 conform to the wellbore shape on expansion of said
18 mandrel.

19 16. The method of claim 6, comprising:

20 pre-cooling said resilient sealing sleeve below
21 ambient temperature before insertion into the
22 wellbore.

23 17. The method of claim 1, comprising:

24 circulating through said string during run in;

25 closing off circulation passages;

26 building pressure in said string;

27 using pressure in said string to expand said at
28 least one isolator, at least in part.

29 18. The method of claim 1, comprising:

30 providing an inflatable on said string to

31 expand said at least one isolator at least in part.

32 19. The method of claim 1, comprising:

- 1 fully expanding said at least one isolator
2 solely with at least one inflatable.
- 3 20. The method of claim 19, comprising:
4 regulating the volume of incompressible fluid
5 delivered to said inflatable as a way to limit
6 expansion of said at least one isolator.
7
- 8 21. The method of claim 19, comprising:
9 using a screen as said tool;
10 expanding said screen against the wellbore wall
11 mechanically.
- 12 22. The method of claim 19, comprising:
13 using a screen as said tool;
14 expanding said screen with said inflatable.
- 15 23. The method of claim 22, comprising:
16 expanding said at least one isolator and said
17 screen in a single trip with said inflatable.
- 18 24. The method of claim 18, comprising:
19 forming said at least one isolator from an un-
20 perforated mandrel covered by a resilient sealing
21 sleeve;
22 initially expanding said mandrel with pressure
23 and then completing the expansion with said
24 inflatable.
- 25 25. The method of claim 22, comprising:
26 pressure testing, after expansion, the seal of
27 said at least one isolator through said screen.
- 28 26. The method of claim 19, comprising:
29 performing said expanding of said at least one
30 isolator and said tool in a single trip into the
31 wellbore.
- 32 27. The method of claim 26, comprising:

1 running in an anchor with said string;
2 setting the anchor before said expanding said
3 inflatable;
4 releasing the string from the anchor before
5 actuation of the inflatable;
6 removing said inflatable from the wellbore with
7 said string.

8 28. The method of claim 18, comprising:
9 forming at least one of said isolators from an
10 un-perforated mandrel covered by a resilient sealing
11 sleeve;

12 initially expanding said mandrel mechanically
13 with a cone-type device and then completing the
14 expansion with said inflatable.

15 29. The method of claim 1, comprising:
16 expanding said tool into contact with the
17 formation; and

18 fracturing the formation by said expanding.

19 30. The method of claim 6, comprising:
20 expanding said tool into contact with the
21 formation; and

22 fracturing the formation by said expanding.

23 31. The method of claim 18 comprising:

24 expanding said tool into contact with the
25 formation; and

26 fracturing the formation by said expanding.

27 32. The method of claim 18, comprising:

28 providing at least two isolators disposed above
29 and below said tool;

30 providing at least one screen as said tool;

31 expanding at least one of said isolators and
32 said screen at least in part with said inflatable.

- 1 33. The method of claim 31, comprising:
- 2 fracturing the formation by said expanding of
- 3 said screen.



Application No: GB 0130640.6
 Claims searched: 1-33

Examiner: Nicholas Mole
 Date of search: 15 April 2002

Patents Act 1977
Search Report under Section 17

Databases searched:

UK Patent Office collections, including GB, EP, WO & US patent specifications, in:
 UK CI (Ed.T): E1F (FJF, FMU, FLW, FJB, FLA)
 Int CI (Ed.7): E21B (43/08, 43/10, 43/14)
 Other: Online: WPI EPODOC JAPIO

Documents considered to be relevant:

Category	Identity of document and relevant passage	Relevant to claims
A	GB 2343691 A (SHELL)	
A	GB 2336383 A (BAKER HUGHES)	
A	EP 0360597 A (HALLIBURTON)	
A, P	US 6263966 B (HAUT)	
A	US 5901789 (DONELLY)	

X	Document indicating lack of novelty or inventive step	A	Document indicating technological background and/or state of the art.
Y	Document indicating lack of inventive step if combined with one or more other documents of same category.	P	Document published on or after the declared priority date but before the filing date of this invention.
&	Member of the same patent family	E	Patent document published on or after, but with priority date earlier than, the filing date of this application.